

SMARTPLATE DOUBLE WALL WATER-TO-WATER HEATER

The AERCO SmartPlate water heater is designed to satisfy potable water heating needs in commercial and institutional environments. The packaged system incorporates simple, easy to understand, real-time, load tracking and responsive controls to maintain accurate hot water temperatures under diversified load patterns.

Packaged with a PID temperature controller and a 3-way electronic control valve, the heater maintains outstanding temperature control when operated under constant load conditions with variances held to $\pm 4^{\circ}\text{F}$ under normal load changes.* An integrated load monitoring system and high turndown electronic control valve deliver accurate temperature control without the need for storage tanks, blending valves or other temperature averaging components. The heater can be remotely monitored and/or fully integrated with BAS software via Modbus communications protocol.

The packaged heater consists of a counter flow, stainless steel, brazed plate, and heat exchanger . the most efficient water-to-water heat exchanger design available for potable water heating. Ideal for use with condensing boilers, the SmartPlate heater utilizes boiler water as little as 5°F above the required potable water temperature, resulting in the highest possible boiler efficiency and minimal radiation losses. To ensure longevity, all water wetted (potable water side) parts are stainless steel, copper or copper alloy materials.

The unit's instantaneous design is compatible with low temperature boiler water. And installation is easy because of its small footprint and doorway size. Single point header connections for Domestic Hot Water, Cold Water, Boiler Water Inlet, Boiler Water Outlet, and electrical power supply are all that is required for a fully functional, safe, and efficient system. Tight temperature control, high thermal efficiency, low maintenance, longevity and overall reliability make the SmartPlate heater the most logical choice for any commercial or institutional domestic water-to-water heating installation.

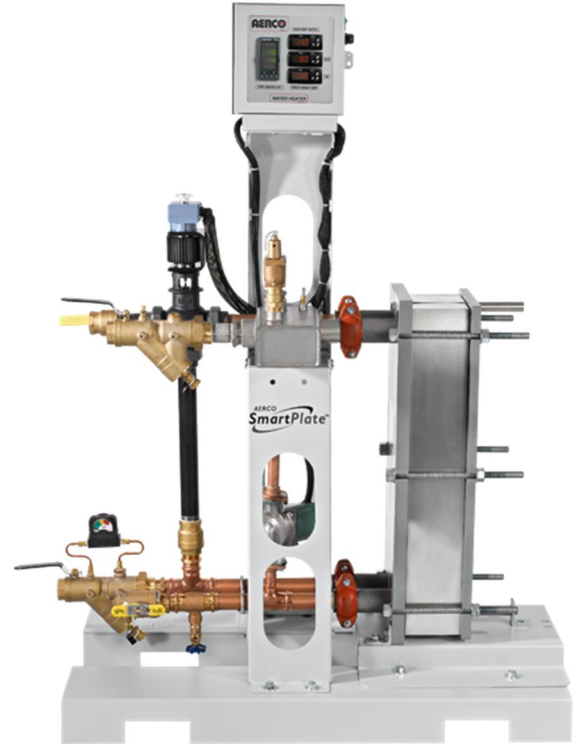

FEATURES

- ~ Accurate Temperature Control $\pm 4^{\circ}\text{F}$ *
- ~ Packaged with 3-Way Electronic Control Valve
- ~ Fully Modulating Variable Primary Input
- ~ Compact Footprint $< 10 \text{ ft}^2$
- ~ All Stainless Steel, Copper or Copper Alloy Wetted (Potable Water Side) Surfaces
- ~ Integral Constant Speed Domestic Water Recirculation Pump
- ~ ASME B&PV Code Section VIII Division 1 Stamped

SUPPORTS MULTIPLE APPLICATIONS

- ~ LTBW; Up to 150 PSIG, 220°F
- ~ Set Point Range 50°F to 180°F
- ~ Single or Multiple Installations
- ~ Supports 2-Way or 3-Way Applications
- ~ Ideal for New or Retrofit
- ~ Swimming Pool Applications (maximum 2ppm free chlorine)

*Incremental change in flow that does not exceed 50% of total capacity; i.e., demand change from 0 to 50% or 20 to 70%

DIMENSIONS

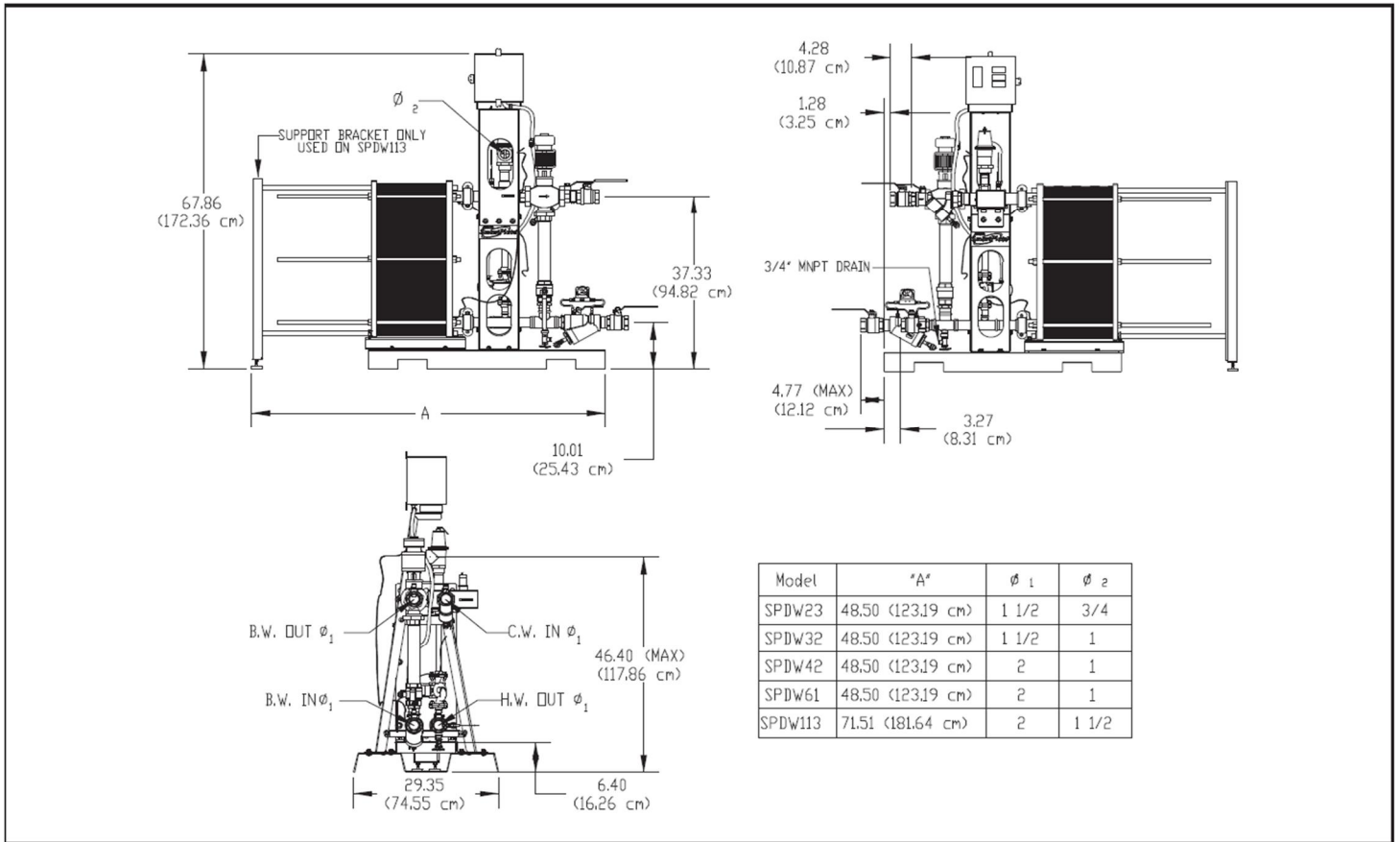

SPECIFICATIONS

Domestic Water Pressure Drop	8PSIG @ max. rated flow
Ambient Operating Temperature	0°F to 131°F
Electrical Requirements	120/1/60 Hz 2 Amp 220/1/50 Hz 2 Amp
Standby Amperage Draw	2 Amp
High Limit "Tripped" Amperage Draw	2 Amp
Max. Continuous Water Flow Rate	90 GPM
Max. Boiler Water Pressure & Temperature	150 PSIG @220°F
Max. Domestic Water Operating Pressure	150 PSIG
Adjustable Temperature Control	up to 180°F
Adjustable High Limit Control	up to 200°F
Water Connection Inlets/Outlets	1.5+FNPT (Models SPDW23 & SPDW32) 2" FNPT (All other models)
Weight (lbs.)	SPDW23 630 (dry), 650 (installed) SPDW32 650 (dry), 670 (installed) SPDW42 720 (dry), 760 (installed) SPDW61 750 (dry), 800 (installed) SPDW113 1160 (dry), 1260 (installed)

AVAILABLE OPTIONS

Dry contacts for remote High Limit Tripped Status+indication.

Represented By:

Specifications subject to change.
Consult website or contact AERCO.
SP-02 Revised 1/7/2011 NJ



WATER HEATERS • BOILERS • PARTS & ACCESSORIES

AERCO INTERNATIONAL, INC. ~ 159 PARIS AVE.
NORTHVALE, N.J. 07647-0128 ~ (201) 768-2400 ~ FAX 201-768-7789
www.aerco.com